

PJ Tech

Metal Detectors

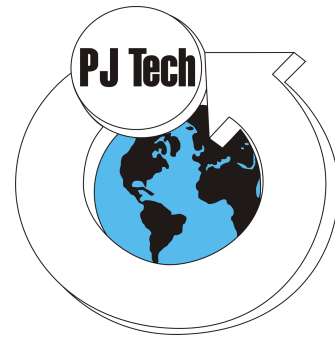

Northlands Business Park
New Market Rd., Northriding
Johannesburg
Republic of South Africa

Tel.: +27 (011) 704-7088 / 9
smart@pjtech.co.za
www.pjtech.co.za

Rev. 3

SMART-100

TRAMP METAL DETECTOR

INSTALLATION INSTRUCTIONS MANUAL

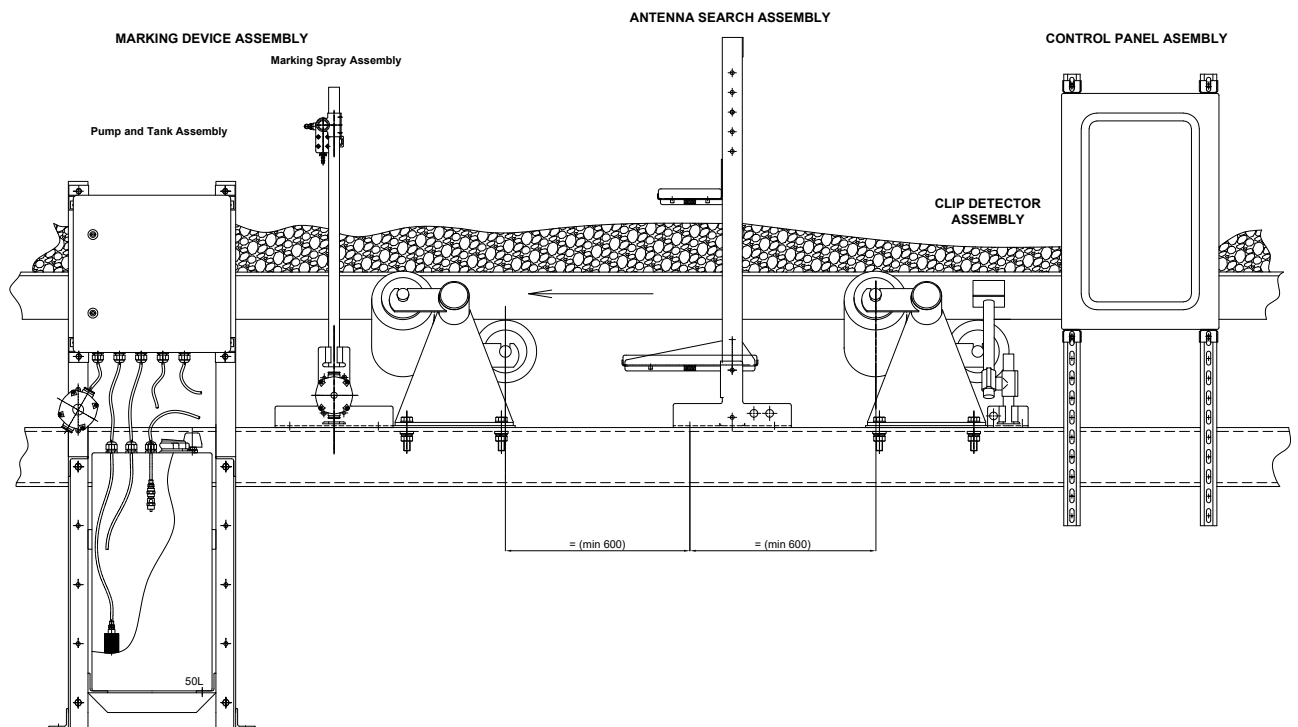

We reserve the right to change contents of this manual due to product innovation or technical improvement



CONTENTS

1	SAFETY	4
1.1	General.....	4
1.2	Safety Signs	4
1.3	Dangers arising from non-compliance with safety notices.....	4
1.4	Installation	4
1.5	Connections.....	4
1.6	Long Term Storage.....	5
2	GENERAL INFORMATION	6
2.1	Standard Warranty	6
2.2	Installation Assistance	6
2.3	Technical Assistance	6
3	SYSTEM DESCRIPTION	7
3.1	Purpose & Features	7
3.2	Method of Operation.....	7
3.3	Physical Description.....	8
3.3.1	Control Unit Enclosure.....	8
3.3.2	Additional Protection Enclosure	9
3.3.3	Electronics Controls.....	10
3.3.4	Antenna Search Frame Assembly.....	11
3.3.5	Clip Detector	12
3.3.6	Dual Clip Detector	12
3.3.7	Spray Marking Device – Pressure Vessel Type.....	13
3.3.8	Spray Marking Device – Pump & Accumulator Type.....	14
3.3.9	Idler Isolation Kit.....	15
3.3.10	Multiple Unit Synchronization	16
4	IMPORTANT NOTES PRIOR TO INSTALLATION.....	17
4.1	Unpacking.....	17
4.2	Site Selection & Preparation	17
4.2.1	Antenna Frame Search Assembly Location	17
4.2.2	Vibration	17
4.2.3	Interferences.....	17
5	INSTALLATION INSTRUCTIONS.....	18
5.1	Idler Isolation.....	18
5.2	Antenna Search Frame Assembly	21



5.3	Main Control Enclosure.....	26
5.4	Swing-Away Switch (if applicable).....	28
5.5	Clip Detector (if applicable).....	30
5.5.1	Single Clip Detector	30
5.5.2	Dual Clip Detector	31
5.6	Spray Marking Device – Compressed Vessel Type (if applicable)	33
5.6.1	Specifications	33
5.6.2	Installation Instructions.....	33
5.6.3	Colorant Solution Re-fill Instructions	34
5.7	Spray Marking Device – Pump & Accumulator Type (if applicable).....	36
5.7.1	Specifications	36
5.7.2	Installation Instructions.....	37
5.7.3	Colorant Solution Re-fill Instructions	38
5.8	Electrical Connection Diagram	41
6	START-UP, SETUP & OPERATION	42
7	SERVICE, PART REPLACEMENT & REPAIRS	43
7.1	Goods Return.....	43
7.1.1	Goods Return Procedure	44
7.2	Electronics	44
7.3	Antenna Search Frame Assembly	45
8	NEW APPLICATIONS	46
9	PJ TECH OTHER SYSTEMS.....	47

SAFETY WARNING !!!

THIS DETECTOR SHOULD BE INSTALLED BY QUALIFIED ELECTRICAL AND MECHANICAL PERSONNEL ONLY.

1 SAFETY





1.1 General

Our equipment conforms to all official technical safety regulations. However, as a manufacturer we believe it is our duty to make you aware of the following information:

- All standard safety procedures should be observed when working on electrically powered equipment.
- Proper care should be taken when connecting or disconnecting the power source.
- When connected to a power source, un-insulated, dangerous voltage is present within the detector's electronics enclosure which may constitute a risk of electric shock.
- Do not allow moisture, steam, plasticisers to collect in the electronics enclosure or near the power connections. Always close the enclosure and secure the locking mechanism after working with the electronics.
- The user should not attempt to service the detector. All servicing should be referred to certified service personnel qualified to work on electrical equipment.

1.2 Safety Signs

Mains voltage runs through the SMART-100 control unit housing and may also be connected to any external electric circuits (e.g., metal alarm relays).

Therefore, the safety sign shown on the right is displayed on the cover of the electronics housing.				
"Mains"		"Direct Out" "Fault" and "Timed Out"		
Observe note 4.5 of the control unit's Operating Instructions Manual when removing the cover during maintenance or repair.				

1.3 Dangers arising from non-compliance with safety notices

Life-endangering electric shocks are likely in cases of non-compliance with the safety notices. 

1.4 Installation

- Do not install this Detector near heat sources such as radiators or air ducts.
- Place the Detector in a location with adequate air circulation to prevent internal heat build-up.

1.5 Connections

As standard, this Detector is set for connection to **100 - 240Vac, 50/60Hz**. Refer to the control unit's Operating Instructions Manual.



1.6 Long Term Storage

For long term storage, the metal detector should be left sealed inside the shipping container and stored in a dry location in temperatures between -10°C and +50°C.



2 GENERAL INFORMATION

SMART 100 tramp metal detector systems are custom fabricated to suit each user's particular application. Each detector system is subjected to extensive testing both at the sub-assembly level and after final assembly to ensure compliance with performance and electrical safety standards.

2.1 Standard Warranty

SMART 100 Control Units/Electronics are warranted against defects in workmanship and materials for **24 months** and the remaining equipment for **12 months**. This warranty does not cover failures due to misuse, neglect, abuse, improper handling, alteration, improper maintenance or accident, and PJ Tech shall not be liable for any direct, indirect, consequential or incidental damages from use, results of use or inability to use this product. Repairs by any other than PJ Tech authorised service personnel will void this warranty.

Within the warranty period, the product will be repaired or replaced at PJ Tech's discretion, free of charge. Except as mentioned above, no other warranty, expressed or implied, applies. If Modules are not covered by warranty as mentioned above, Dealer/User will be billed for set up charge on the loaner, shipping and repair. Warrantee status will be determined by PJ Tech personnel only.

2.2 Installation Assistance

SMART 100 detectors have been designed for installation by qualified personnel with detailed instructions provided with each delivery. When required, a PJ Tech Site Engineer will supervise or check the installation, activate the system and provide training on periodic adjustments and care of the Detector for user maintenance personnel. Please contact PJ Tech for Site Service rates.

2.3 Technical Assistance

PJ Tech welcomes your inquiries concerning metal detectors and their application, installation and servicing. If technical or application assistance is needed, contact us directly or your local distributor:

- smart@pjtech.co.za
- www.pjtech.co.za
- +27 11 704 7088

3 SYSTEM DESCRIPTION

3.1 Purpose & Features

SMART-100 provides protection to downstream processing equipment by detecting the presence of potentially damaging metal objects. It is designed for use on conveyor systems carrying materials which contain consolidated or fractured magnetic or non-magnetic ore, as well as ores ranging in electrical conductivity. The Detector will discriminate between these conveyed materials and tramp metal of any type: ferrous, non-ferrous, magnetic or non-magnetic.

The Detector makes use of the latest digital electronic technology. The design includes a number of innovative features, e.g.:

- Self-test circuits that monitor the performance of the detection circuitry, which when they fail, will trigger a Fault Relay.
- Wide programming capability to custom tailor the Detector to suit specific application requirements.
- Multi language support.

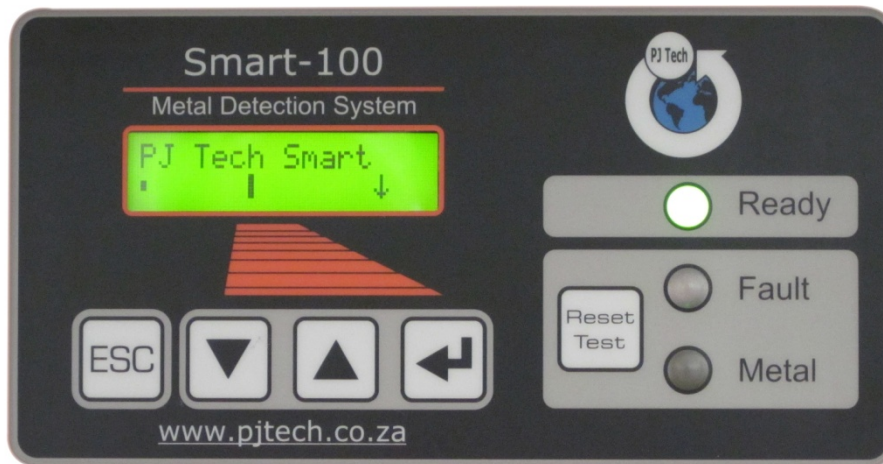

Control Unit's User Interface – Faceplate

3.2 Method of Operation

During normal operation, the transmitter coil is energised to produce a pulsed electromagnetic signal. These signals produce a field that permeates the conveyed material between the antennas. A piece of metal entering this field absorbs energy emitted from the transmitter coil. The metal particle then releases the energy and it is detected by the receiver coil. This technique provides optimum discrimination between tramp metal and the conveyed material; product effect is non-existent or minimal.

Having detected metal by a waveform change, the signal generated is amplified and filtered. The signal is then compared to a threshold determined by the size of metal that must be detected. When the signal exceeds this threshold, the Detector, at the appropriate time, triggers the output relays.

Due to the fact that the Detector is influenced only by the change, the stationary structures, metal belt cords, symmetrical idlers and other objects which do not represent a moving mass to the field are not detected. If used, the metal belt steel repair clips can be ignored by use of our optional, properly adjusted clip detector sensor. The clip detector attenuates the Detector's sensitivity while the clips pass through the antennas.



3.3 Physical Description

3.3.1 Control Unit Enclosure

All the electronics and controls for the Detector are housed in the steel IP65 rated Electronics Please refer to Figure 1 for enclosure's dimensions:

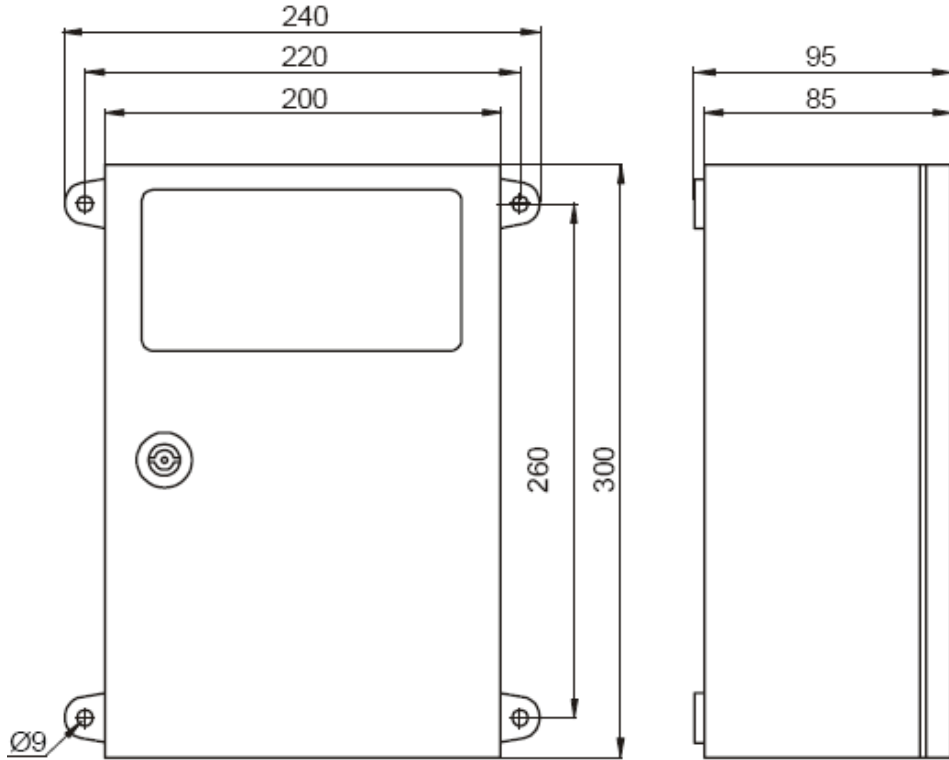

All dimensions in mm

Figure 1

3.3.2 Additional Protection Enclosure

This additional plastic IP65 rated protection enclosure houses and protects the Control Unit Enclosure. The Electronics of the Control Unit is wired to the field terminals of this enclosure. This enclosure also serves as an interface between the Control Unit (electronics) and all field cables such as the transmitter antenna, receiver antenna and other field equipment that is specific to the given application, e.g., marking device, remote reset button, etc. Refer to Figure 2 for protection enclosure's general layout and Figure 17 for a complete drawing:

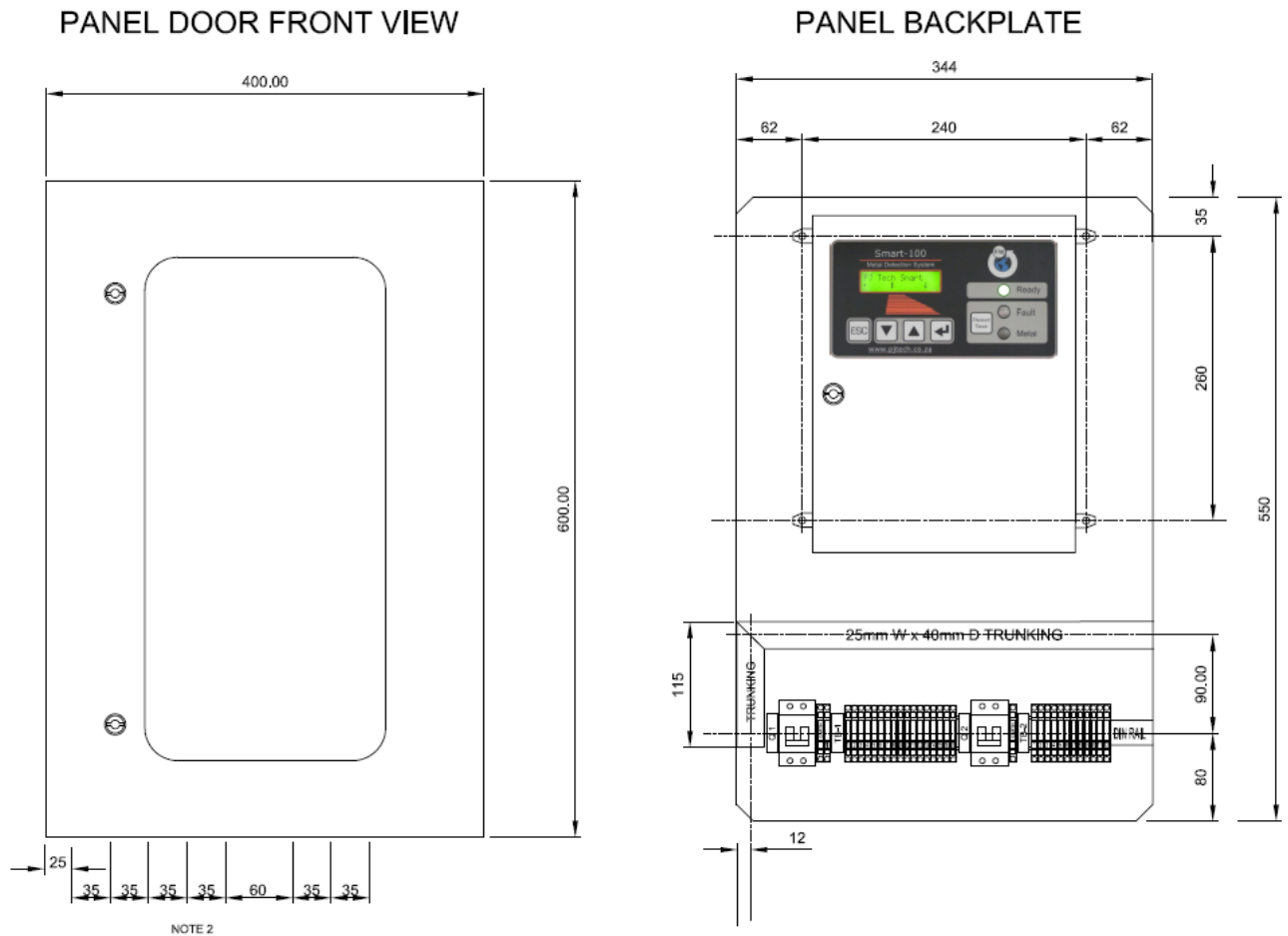
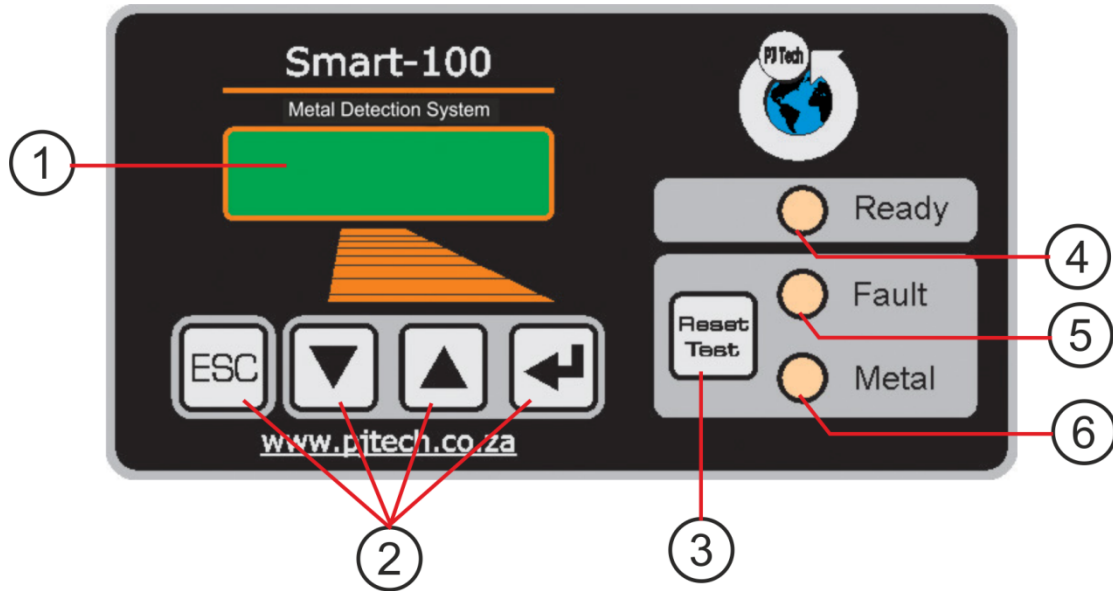

Figure 2

3.3.3 Electronics Controls

All electronic control functions are performed using the front control panel. These functions are performed using control buttons (2 & 3) and are visible on an LCD screen (1). Refer to Figure 3 for general layout of the faceplate (User interface):



1	LCD screen	2 lines, 32 characters	For operation and machine setup
2	Operator keys	ESC, UP, DOWN and ↵ (Enter) buttons	For operation and machine setup
3	Function key	Reset / Test button	Reset to restore the unit after metal or fault signal
4	Green light	Operating	Illuminates when supply voltage is present
5	Red light	Fault	Flashes when fault is detected
6	Yellow light	Metal	Illuminates when metal is detected

Figure 3

3.3.4 Antenna Search Frame Assembly

The Antenna Search Frame Assembly includes receiver and transmitter antennas, mounting frame and interconnecting cables. Each assembly is custom designed to suit its particular application. Please refer to Figure 4 for the Antenna Search Frame Assembly photo.

A) Receiver Antenna

The receiver antenna is typically located under the conveyed material within 50mm of the loaded conveyor belt.

B) Transmitter Antenna

The transmitter antenna is located above the conveyed material, opposite and parallel to the receiver coil. The distance between the transmitter and receiver antennas (aperture) is typically 100mm greater than the maximum burden depth of the processed material but it may vary depending on the application.

C) Mounting Frame

The mounting frame supports the antennas on trough and slider bed conveyors. Special designs are available to accommodate other types of material handling systems. The swing-away assembly, shown in Figure 4, protects the transmitter from oversized conveyed materials.

D) Interconnecting Cables

Shielded cables connect the receiver and transmitter to the Main Control Unit/Electronics Enclosure. Cable of 7.5m long between the frame assembly and electronics is supplied as standard for both receiver and transmitter antennas. Optimum performance is assured with cable lengths of 7.5m or under. However, lengths of up to 30m are acceptable where detector sensitivity requirements are minimal.

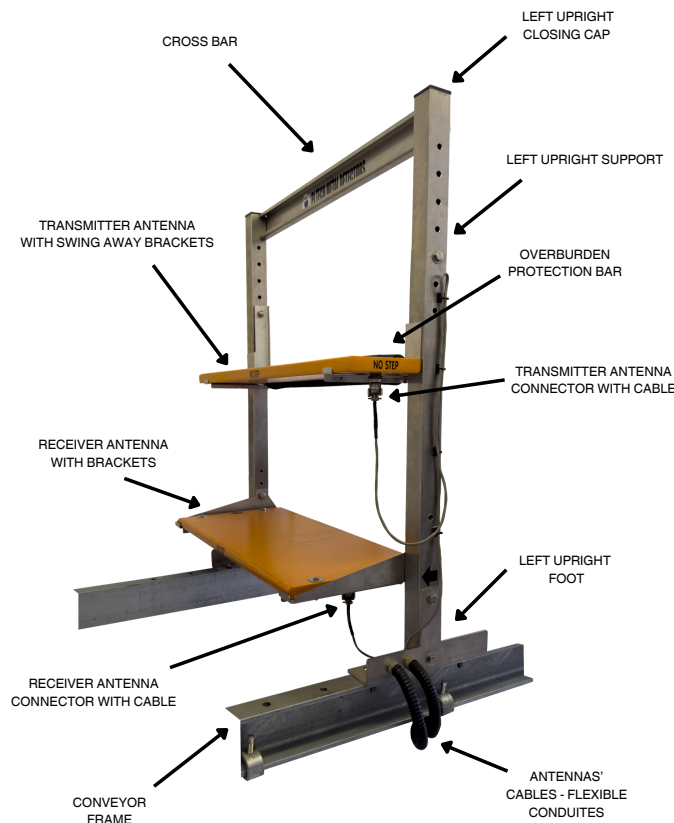

Figure 4

3.3.5 Clip Detector

The clip detector consists of a compact sensor head and mounting swivel bracket. The clip detector senses the proximity of repair clips as they pass over the sensor's head. Once the clips are detected, the Metal Detector is desensitised, but not disabled. Any large piece of metal being conveyed on the clips will still trigger the Detector. Refer to Figure 5 & 6 for details and Figure 23 for electrical connections.

Head Size	:	84mm x 84mm x 40mm
Head Weight	:	570g
Cable Length	:	7.5m



Figure 5

3.3.6 Dual Clip Detector

Dual clip detectors are used on slow moving conveyors when the time it takes the clips to transition through the antenna zone is greater than maximum clip time (30 sec.) of the controller, or variable speed conveyors where the time for the clip to pass through the detector could vary. One clip detector is mounted upstream of the first upstream adjacent idler roller and the second is mounted downstream of the first downstream adjacent idler roller. The clip detectors are labelled "Upstream" and "Downstream" to indicate the location they should be placed. Refer to Figure 5 & 6 for detail and Figure 23 for electrical connections.

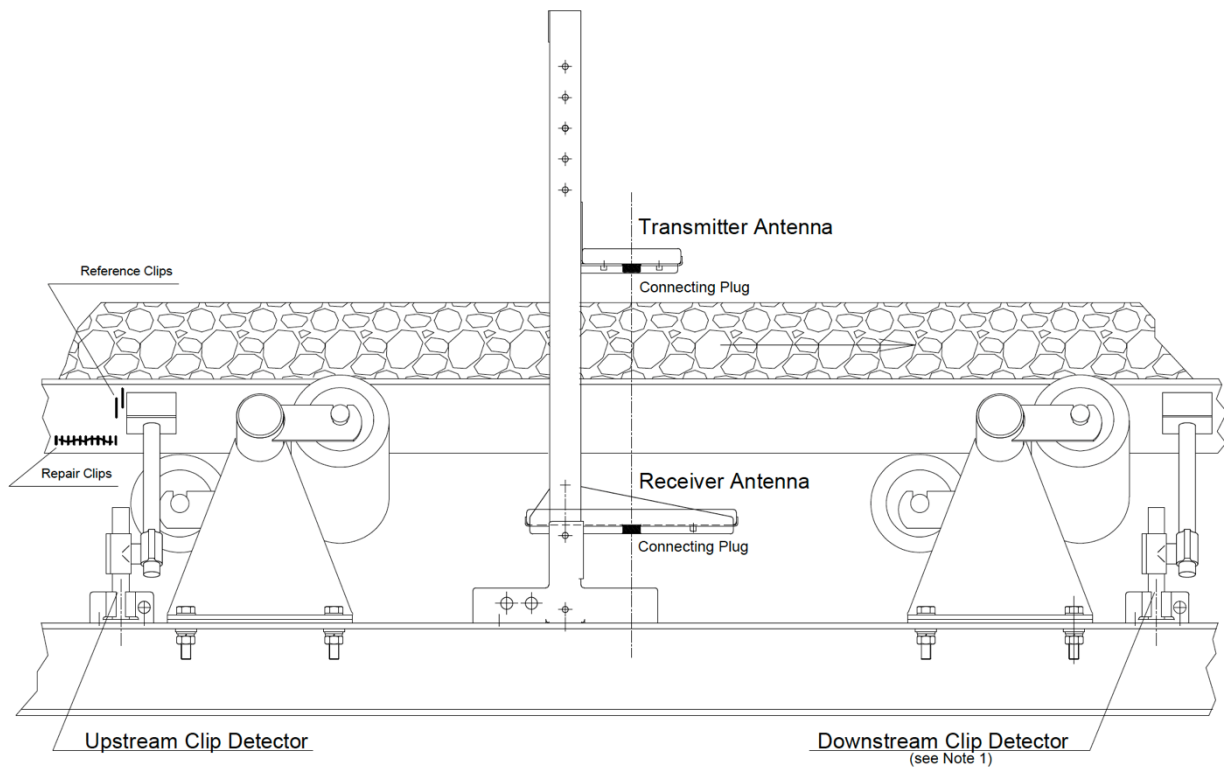

Figure 6

3.3.7 Spray Marking Device – Pressure Vessel Type

This Spray Marking Device is a pressurised, solenoid valve activated liquid spray system which pinpoints the location of tramp metal to eliminate costly search and down time. Refer to Figure 7a for details and Figure 23 for electrical connections.

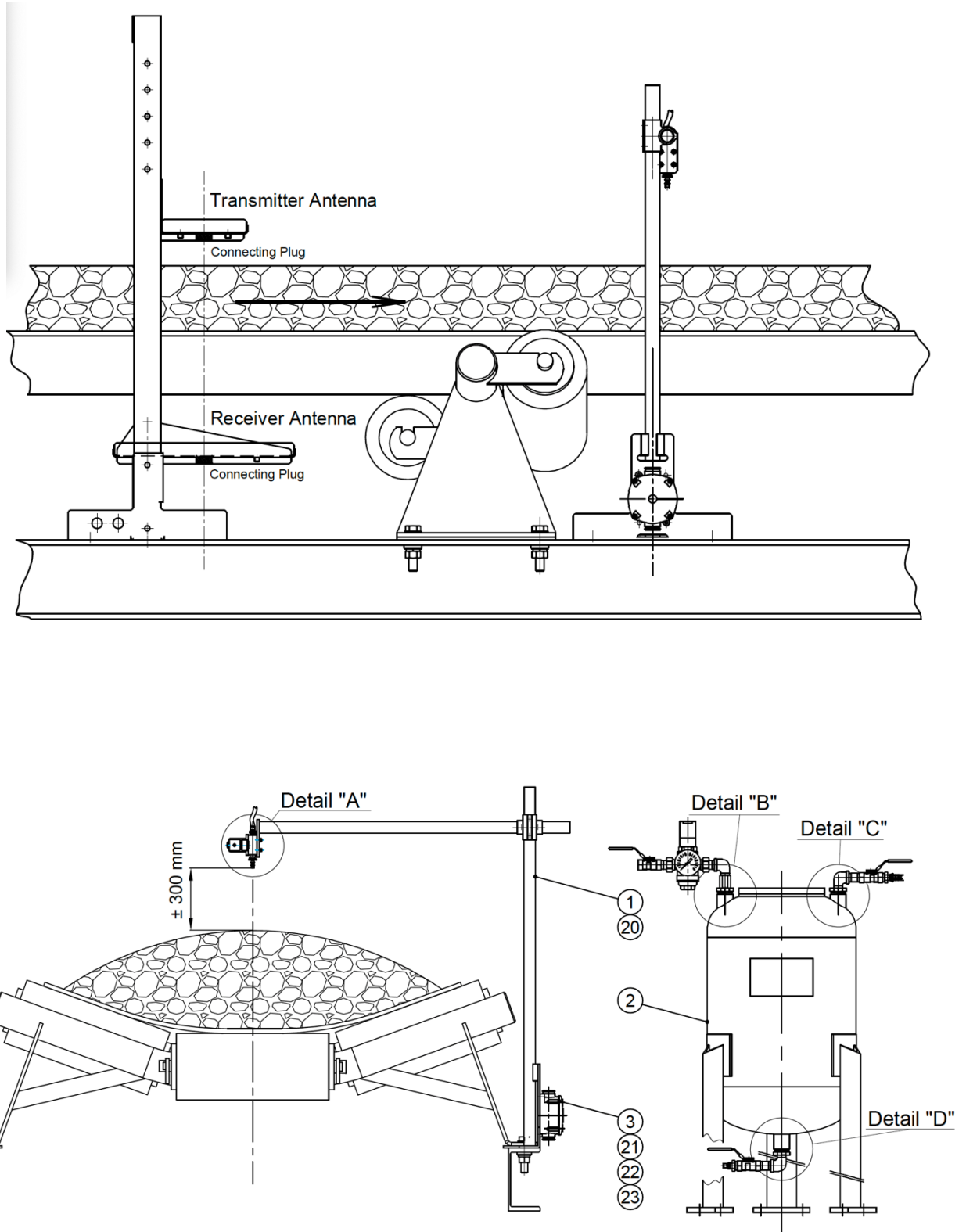

Figure 7a

3.3.8 Spray Marking Device – Pump & Accumulator Type

This Spray Marking Device is a pressurised (pump + accumulator), solenoid valve activated liquid spray system which pinpoints the location of tramp metal to eliminate costly search and down time. Refer to Figure 7b for details and Figure 23 for electrical connections.

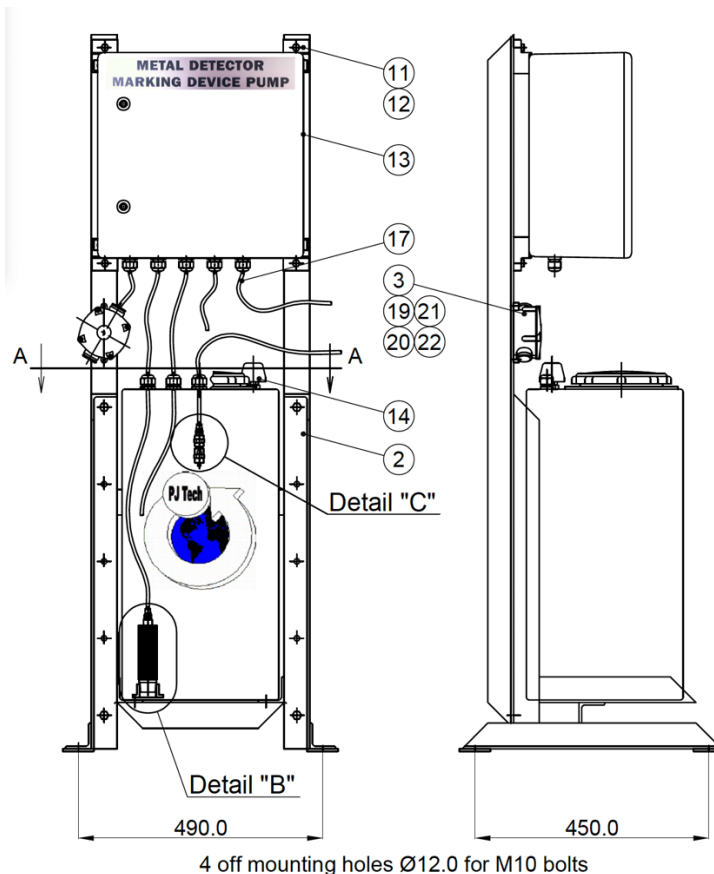
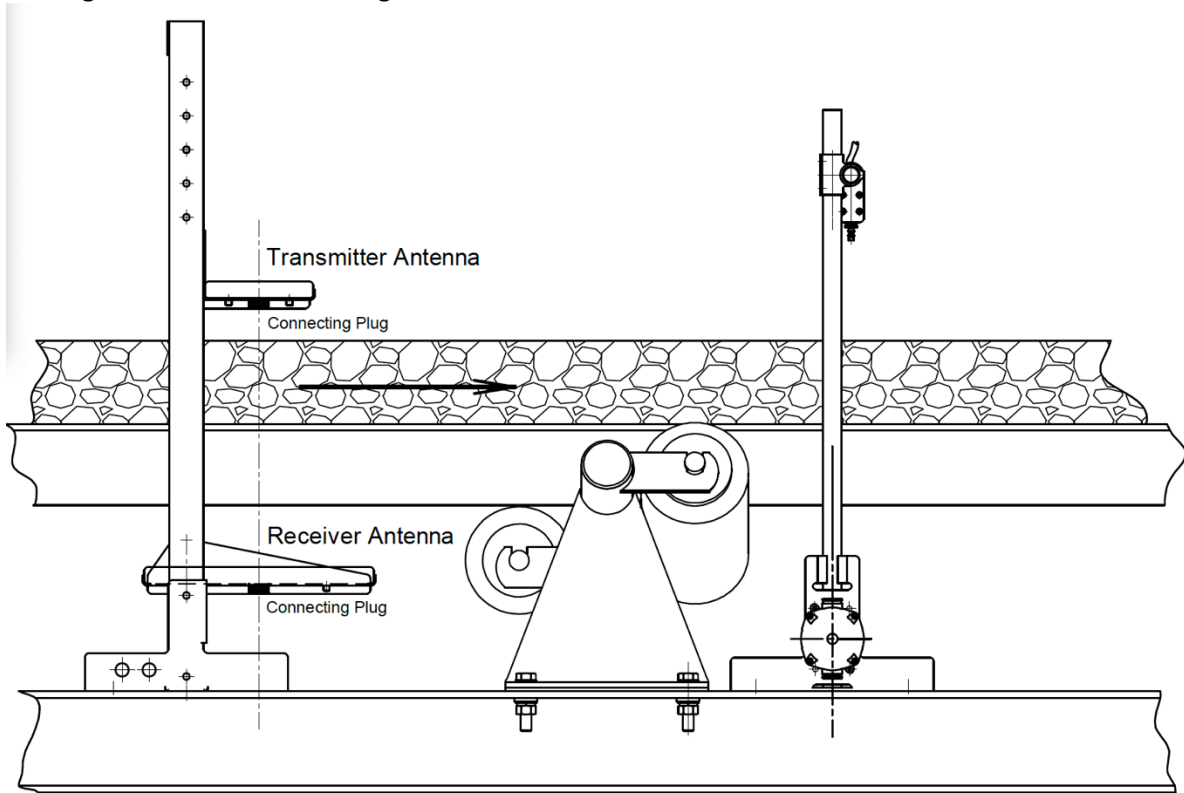

Figure 7b

3.3.9 Idler Isolation Kit

The idler isolation kit is used to reduce or eliminated unwanted electrical interference from the adjacent idler rollers. Refer to Figure 8 & 9 for details:

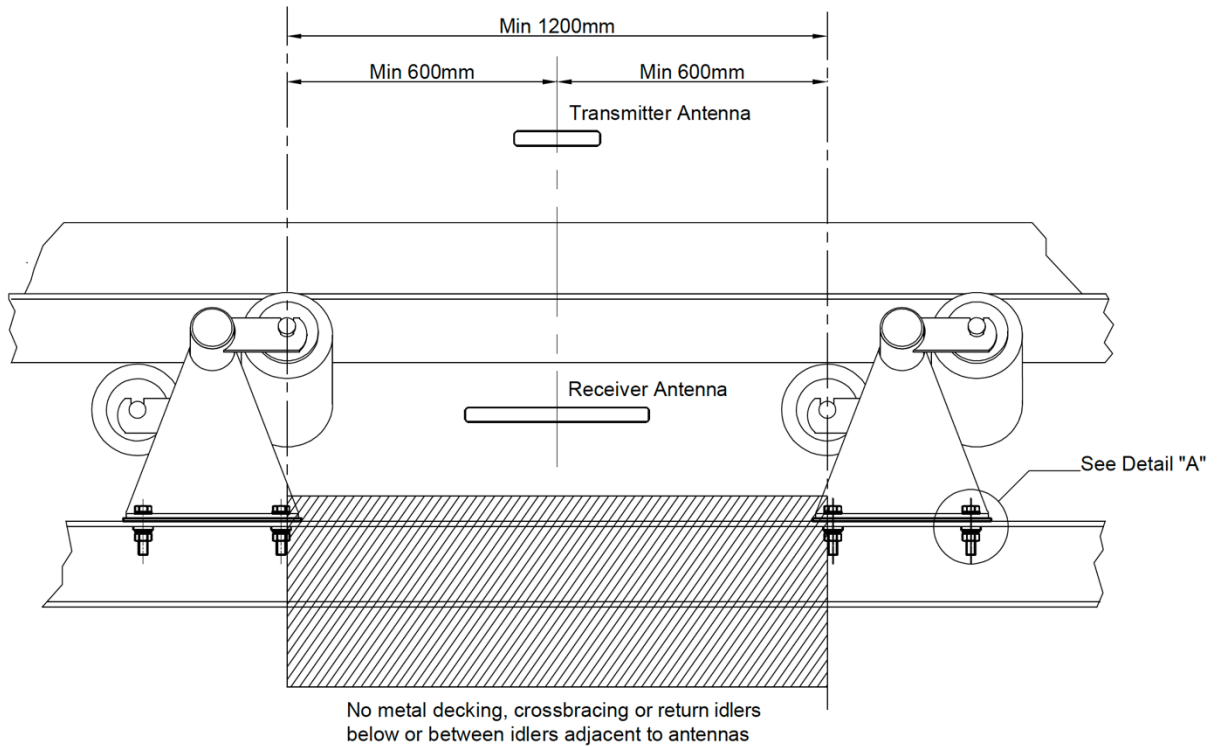
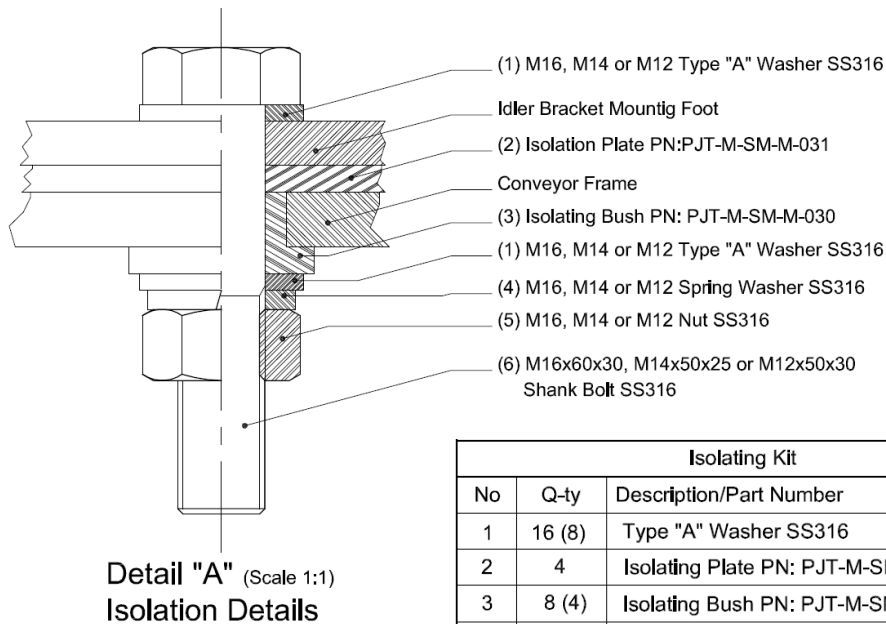

Figure 8



Isolating Kit		
No	Q-ty	Description/Part Number
1	16 (8)	Type "A" Washer SS316
2	4	Isolating Plate PN: PJT-M-SM-M-031
3	8 (4)	Isolating Bush PN: PJT-M-SM-M-030
4	8 (4)	Spring Washer SS316
5	8 (4)	Nut SS316
6	8 (4)	Shank Bolt SS316
Quantities depend on idler feet bolting arrangement (single or double bolts)		

Figure 9



3.3.10 Multiple Unit Synchronization

Synchronization is used when two metal detectors are used within 30m of each other and are within a line of sight. Exception is when there is a metal wall or other metal structure between the two metal detectors to absorb the signals from the metal detectors. Refer to Figure 23 for electrical connection details.



4 IMPORTANT NOTES PRIOR TO INSTALLATION

PLEASE READ THROUGH COMPLETELY BEFORE BEGINNING INSTALLATION WORK!

4.1 Unpacking

Upon receipt of the crate(s) containing the Metal Detector System, inspect the contents for physical damage and missing parts. If anything is broken or missing, please contact the carrier and notify PJ Tech immediately.

4.2 Site Selection & Preparation

While each application is unique, the guidelines listed below apply to most installations. Specific information concerning your installation can be found in the Antenna Search Frame Assembly and Control Connection Diagrams (refer to Figure 4 & 23). Follow the steps listed below to choose the best location for the detector:

4.2.1 Antenna Frame Search Assembly Location

Choose a location for the detector so the material handling system has ample time to react to tramp metal. Locate the detector far enough in advance of the head pulley so the belt can come to a stop before the metal falls off the end of the belt. If a diverter is used, consider the reaction time of the system and speed of the conveyor belt.

4.2.2 Vibration

Select a location with minimum vibration. High vibration areas may degrade detector sensitivity and shorten component life.

4.2.3 Interferences

Locate the Antenna Search Frame Assembly away from sources of airborne electrical interference emitted from variable-speed drives, large motors, ballasts, FM radios, induction furnaces and other radio frequency (RF) sources. Because RF energy travels along a straight line (line-of-sight), position the receiver coil or relocate RF sources so they are out of the direct line-of-sight with the top and bottom of the receiver coil. Cables carrying high voltage or varying loads must be enclosed in steel conduit, grounded at both ends and located at least 1.2m from the detector antennas.

If the Antenna Search Frame Assembly is located where a metal skirt passes through the antennas, it must be replaced with approximately 1500mm section of non-metallic material (i.e., wood or plastic).

Remove metallic decking, skirt boards, cross bracing and return idlers below and within approximately 1000mm of the centre line of the receiver coil (upstream and downstream). Relocate or tightly secure moving or vibrating pieces of metal such as cables, conduit and piping within approximately 1000mm of the Antenna Search Frame Assembly.

5 INSTALLATION INSTRUCTIONS

PLEASE READ THROUGH SECTION 4 BEFORE BEGINNING INSTALLATION WORK!

5.1 Idler Isolation

The magnetic field generated by the transmitter coil induces eddy currents in nearby metal cross bracing, stairways, handrails and pipes. These eddy currents may cause false tripping if the current path intermittently makes contact. Eddy current loops can be broken by cutting the conductive paths in these structures. Use non-metallic hardware as required to restore structural support. If conveyor idlers are used in your application, the idlers adjacent to the Antenna Search Frame Assembly may require modification or isolation to break eddy current loops. An Idler Isolation Kit has been provided with your detector for this purpose. For installation details refer to Figures 11, 12 and Figure 13 for the complete drawing. The Idler Isolation Kit consists of the following (Figure 10):

Isolating Kit		
No	Q-ty	Description/Part Number
1	16 (8)	Type "A" Washer SS316
2	4	Isolating Plate PN: PJT-M-SM-M-031
3	8 (4)	Isolating Bush PN: PJT-M-SM-M-030
4	8 (4)	Spring Washer SS316
5	8 (4)	Nut SS316
6	8 (4)	Shank Bolt SS316

Quantities depend on idler feet bolting arrangement (single or double bolts)

Figure 10

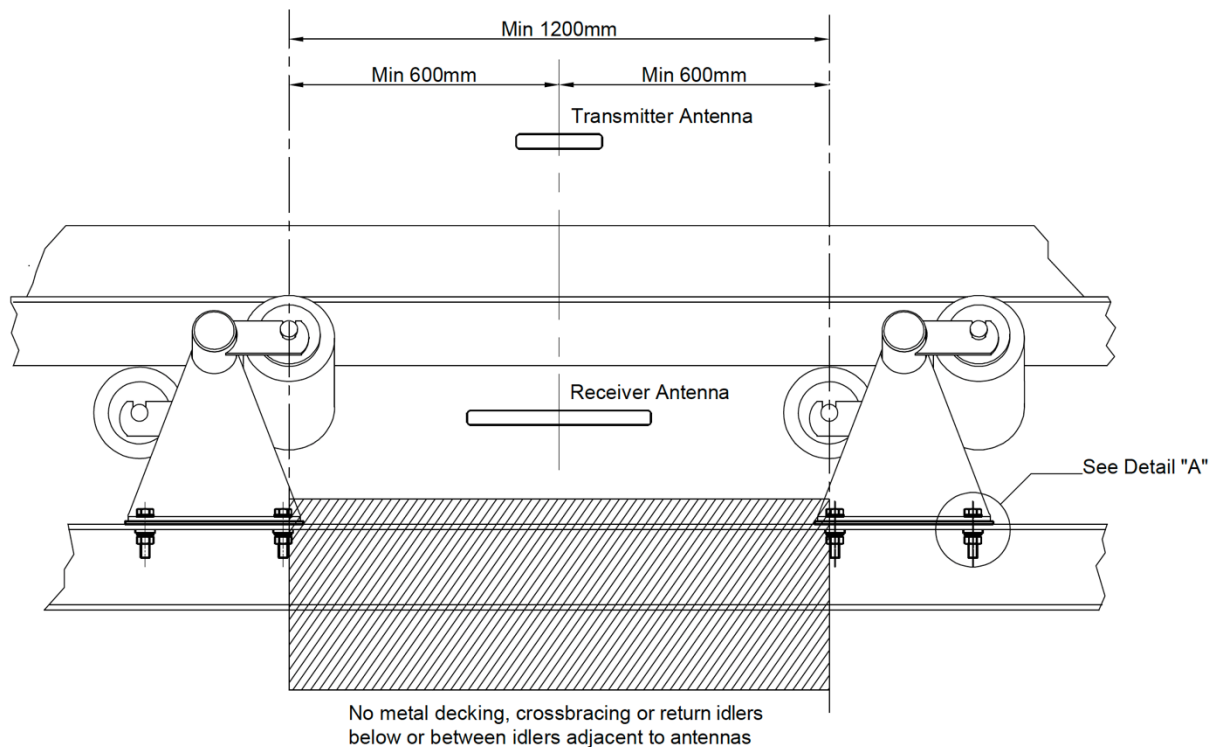

Figure 11

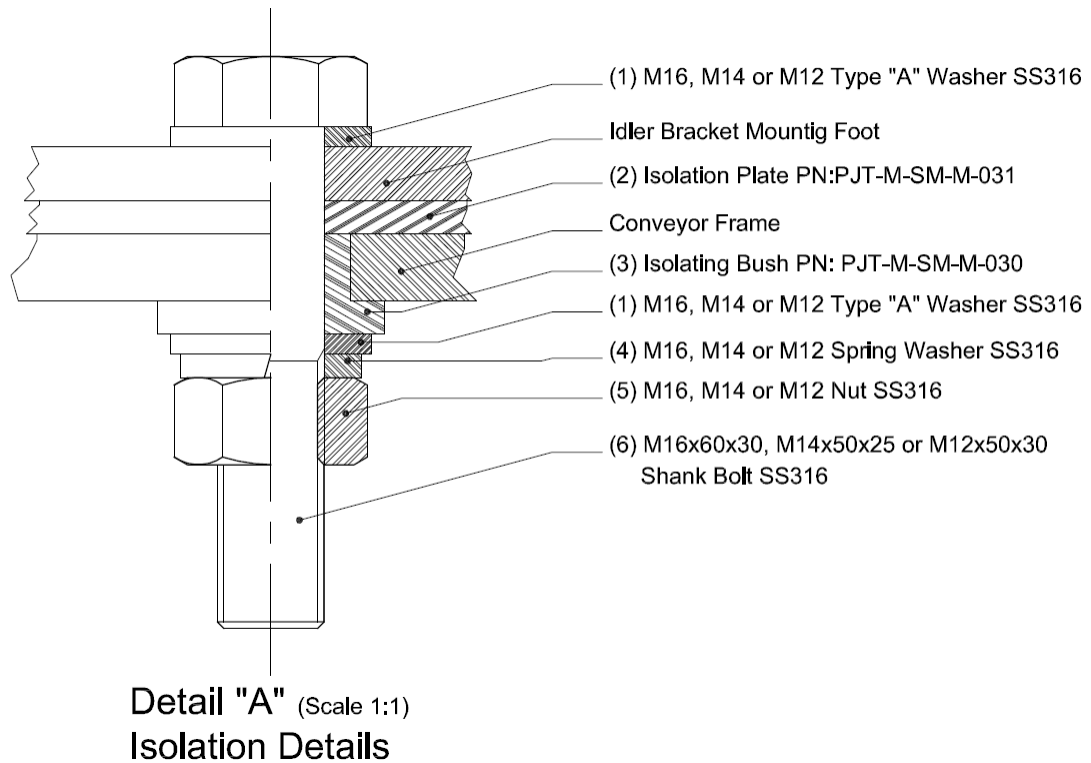

Figure 12

- A) Remove the adjacent idler feet on either side of the detector's installation location.
- B) Drill 17mm diameter holes in the four isolating plates, matching the mounting holes in idler mounting feet. If necessary, drill the holes in the feet to 12mm, 14mm or 16mm diameter (depending on the bolt size being used to fasten the idler feet).
- C) Drill the corresponding 25mm diameter holes in the conveyor frame where the idlers' feet must be mounted.
- D) Check the length of the isolating bush and shorten it if necessary.
- E) Re-mount the idler feet so that the isolating plates are sandwiched between the idler feet and conveyor frame. For the mounting arrangement see Detail "A" (Figure 12).

5.2 Antenna Search Frame Assembly

Note the movement direction arrows, match marks and other identification on the Detector components before beginning work. Please refer to the Figure 14 & 15 and photos for installation, Figure 16 for complete drawing and Figure 23 for electrical connection diagram.

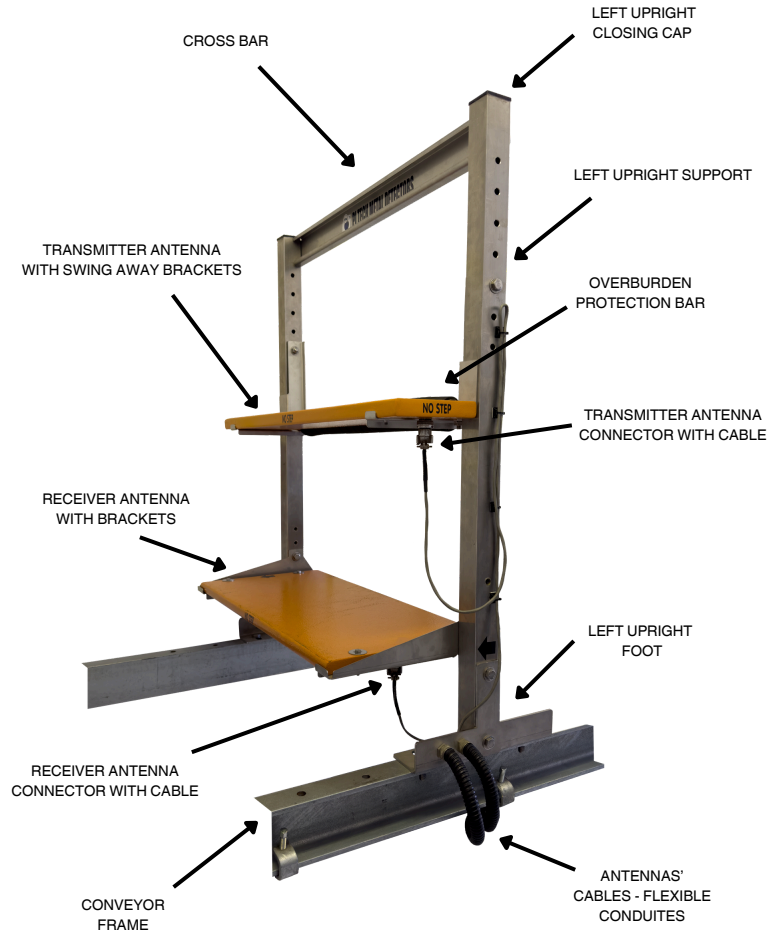

Figure 14
(all items supplied as standard, except for conveyor frame)

- A) Assemble the top crossbar to the 2 vertical uprights using 4 off M10 x 25mm bolts with M10 washers to clinch nuts (upgraded versions use 6 off). Ensure the crossbar is located on the upstream side of the upright supports and the base of the metal mounting feet angles point in toward the belt.



Assembled Crossbar (right)

- B) Assemble the top transmitter coil (with fitted swing-away brackets) to the 2 uprights, as per below photos:



*Assembled Transmitter Swing Away Antenna Bracket
(right)*



*Transmitter Swing Away Antenna Bracket
Mounting Details (right)*

The height of the transmitter coil should be as low as possible without being hit by overburden.

From outside of one of the uprights, insert M10x75mm bolt with M10 flat washer. On the opposite side of this upright, insert 2 off M10 flat washers onto the protruding bolt (rounded side to rounded side for swivel effect). Then insert that bolt into the hole of matching antenna bracket, insert M10 flat washer and screw on M10 nyloc nut (nylon-insert lock nuts). Repeat these steps on the other upright.

Tighten nyloc nuts until light drag is exerted on the swing-away bracket. Verify that the swing-away brackets can move freely.

CAUTION:

If the swing-away assembly cannot move freely, damage to the transmitter coil may result if hit by overburden!

- C) Position the upright assembly onto the conveyor frame with the arrow on the transmitter coil pointing in the direction of belt movement.
- D) Assemble the receiver coil (with fitted mounting brackets) to the upright supports using 4 off M10x25mm bolts with M10 flat washers. Position the height of the receiver coil approximately 50mm below the belt. In application with highly conductive ores, this distance can be increased. Allow for belt sag under load.



*Assembled Receiver Antenna
(right)*

- E) Verify that the Antenna Search Frame Assembly is square and all bolts installed are properly tightened.
- F) **Position the entire Antenna Search Frame Assembly so that the bottom of the coil (the receiver) is equally spaced between the two adjacent idler rollers. Centre the receiver coil as per Figure 16.** Refer to the hole indicating centre line that is punched on both square uprights' steel feet.

CAUTION:

DO NOT CENTRE the 50mm x 50mm UPRIGHTS!

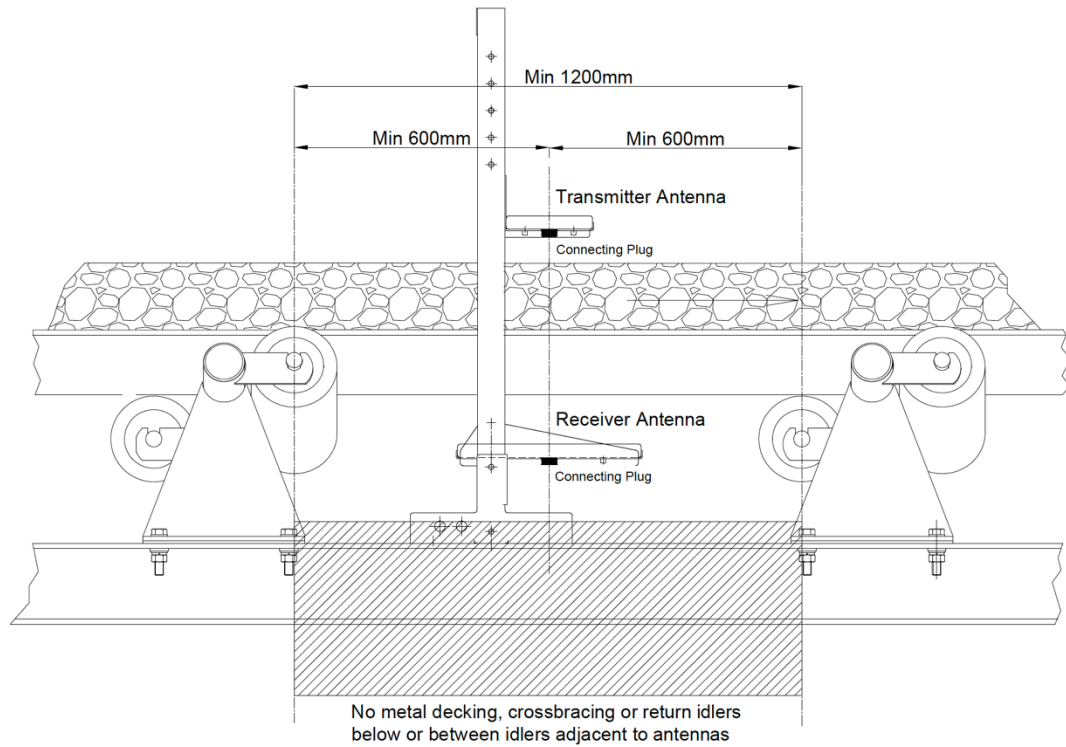

Figure 15

- G) Bolt the metal support feet to the conveyor frame with supplied bolts, nuts and washers. Be sure that any unwanted twists and torques in the frame assembly are corrected before you proceed. **A twist in the frame may cause the swing-away bracket to pull away from the upright support. This may cause the transmitter coil to bounce from vibration while in operation.**



5.3 Main Control Enclosure

After installing the Antenna Frame Search Assembly, select a place to mount the Main Control Enclosure for ease of operation. As standard, the electronics steel IP65 rated enclosure is mounted inside the additional plastic IP65 rated field protection enclosure. The Control Unit/Electronics is wired to the field terminals of this enclosure. This enclosure also serves as an interface between the Control Unit/Electronics and all field cables such as the transmitter antenna, receiver antenna and other field equipment that is specific to the given application, e.g., marking device, remote reset button, etc. Refer to Figure 17 for general layout drawing and Figure 23 for connection diagram drawing.

CAUTION:

Avoid high vibration areas. Note the length of interconnecting cables and the location of the connectors on the coil. Locate the Control Enclosure on the same side of the conveyor frame as the connectors for ease in routing the cables!

- A) The Control Unit/Electronics Enclosure should be positioned so the front panel hinge is on the Right side and the display is on top.
- B) Familiarise yourself with the type of electrical connections required for this installation and any safety precautions before proceeding. Refer to Control Connection Diagrams for connection details. Use provided wire tags while connecting all the cables.
- C) Use the existing conduit holes on the bottom of the Enclosure. Use caution to not damage the electronics and to ensure that no metal particles enter the electronics. Do not run metal conduit along the sides or near the Antenna Search Frame Assembly.
- E) Transmitter and receiver cables should be routed in flexible conduit, for protection of the cables. **Do not run any power wiring in the same conduit or near the transmitter and receiver cables.**



Main Control Enclosure



5.4 Swing-Away Switch (if applicable)

The Swing-Away Cut-off switch (Optional) is a pre-wired switch mounted on the swing-away bracket. Its purpose is to prevent the Metal Detector from tripping when the transmitter coil is hit by an overburden of material. Route the free end of this cable in the same flexible conduit as the transmitter cable to the Main Control Enclosure. Refer to Figure 18 for complete assembly drawing and Figure 23 for connection diagram drawing.

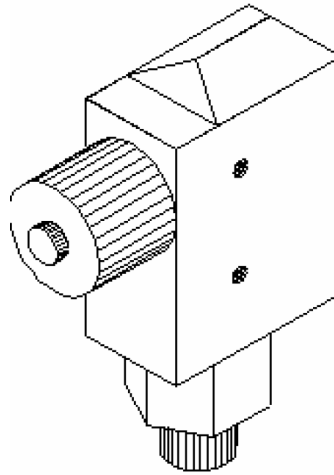

Swing Away Switch

5.5 Clip Detector (if applicable)

The clip detector senses the proximity of repair clips as they pass over the sensor's head. Once the clips are detected, the Metal Detector is desensitised, but not disabled. Any large piece of metal being conveyed on the clips will still trigger the Detector.



*Clip Detector
(complete assembly)*

5.5.1 Single Clip Detector

Refer to Figure 19 for complete drawing and Figure 23 for connection diagram drawing. Install the clip detector unit as follows:

- A) If there are idlers adjacent to the search coils, position the Clip Detector Sensor approximately 50mm upstream of the nearest upstream idler before the Antenna Search Frame Assembly. For slider bed type conveyors, position the Clip Detector Sensor approximately (but no closer than) 650mm from the centre line of the receiver coil on the upstream side of the Antenna Search Frame Assembly. The flat face of the Clip Detector should be facing toward the belt with approximately 15mm to 25mm of clearance. **This clearance must be maintained in order to assure proper operation.** The Clip Detector should be approximately 50mm from the edge of the belt. Do not mount the Sensor too far from the edge, as tramp metal lying close to the belt may trigger the sensor and pass through the search coils as a repair splice.
- B) With the Clip Detector Sensor in the proper position below the belt, bolt or weld the 3/4" support pipe (provided) to the conveyor frame. The pipe may be cut to the proper length for an easier fit. The multi-axis swivel joint will provide adequate movement for proper adjustment.
- C) It is recommended that the Clip Detector cable running to the Main Control Enclosure be installed in flexible conduit (provided). The same flexible conduit that houses the transmitter coil cable may be used but separate conduit is recommended.
- D) Feed the Clip Detector cable into the conduit from the Clip Detector end to the Main Control Enclosure. Cut off excess cable. Connect wires to terminal block (TB2). Refer to 21 for connection diagram. Be certain all wires are attached securely, tagged with provided wire tags and connected to their designated terminals.



- E) In case where metal repair clips do not run through the entire belt width then two or three reference clips must be used to activate the Clip Detector. Reference clips are made by installing two or more clips which will pass directly over the Clip Detector Head to trip it when a small patch passes by, refer to Figure 19. Numerous repair and reference clips on the belt will degrade the Detector's performance because it will frequently be in a desensitised mode.

5.5.2 Dual Clip Detector

Dual clip detectors are used on slow moving conveyors when the time it takes the clips to transition through the antenna zone is greater than maximum clip time (30 sec.) of the controller electronics, or variable speed conveyors where the time for the clip to pass through the detector could vary. One clip detector is mounted upstream of the first upstream adjacent idler roller and the second is mounted downstream of the first downstream adjacent idler roller. The clip detectors are labelled "Upstream" and "Downstream" to indicate the location where they should be placed.

This Clip Detector must be installed approximately 50mm downstream of the nearest downstream idler after the Antenna Search Frame Assembly. Refer to section 5.5.1 - Single Clip Detector for installation details.



5.6 Spray Marking Device – Compressed Air Vessel Type (if applicable)

The Marking Device is a pressurised, solenoid activated liquid spray system which pinpoints the location of tramp metal to eliminate costly search and down time.

5.6.1 Specifications

Vessel Pressure Rating:	:	8bar (maximum working pressure), pressure test certificate provided
Capacity:	:	50L
Operational Voltage (spray valve):	:	110 or 220 VAC (50/60 Hz), 8W
Compressed Air Supply:	:	Plant air or any source of 5 to 8 bar inert gas

5.6.2 Installation Instructions

- A) Refer to Figure 20 for installation detail and Figure 23 for connection diagram.
- B) Assemble the Marking Device Adjustable Spray Frame (1) upright and cross arm with the cross bracket.
- C) Fasten the solenoid valve with the spray nozzle (Detail “A”) and factory connected 3m cable to the cross bracket with the provided screws and connect the cable to the connectors in the Pratley box. Ensure the excess cable is coiled to allow future adjustments and that the spray nozzle points down, directly above the centre of the conveyor belt.
- D) Connect the 6mm tubing to the solenoid valve (Detail “A”). Ensure the excess tubing is coiled to allow future adjustments.
- E) Position the Adjustable Spray Frame upright and cross arm as shown (1). It should be located approximately 1m to 2m from the antenna coils. Bolt the bottom of the Adjustable Spray Frame to the conveyor frame. If necessary, first clamp it in place temporarily.
- F) Connect the cable between the Pratley box (3) and the field terminals in the Main Control Enclosure (10m SWA, 1mm², 1 pair cable provided). Route the cable accordingly and cut off excess cable.
- G) Connect the tubing between the tank outlet (19) and the solenoid valve (5). Ensure that ½” isolation valve is also mounted at the vessel’s outlet (Detail “D”).
- H) Mount ½” non-return valve (24) and pressure regulator with pressure gauge (14&13) on the vessel’s air inlet and connect compressed air source to the isolation valve as shown. **Ensure that the air source is shut off and there is no pressure is in the vessel.**
- I) Mount ½” air pressure relief valve as shown (Detail “C”).
- J) Remove the vessel’s lid and ensure that the 1” 25-micron S/S strainer (17) is screwed in (inside the vessel, at the bottom). This strainer protects the spray solenoid valve from solid particles that might be within the compressed supply airline.



- K) Ensure that ½” rubber reinforced hose (16) is connected to the air inlet and its end rests at the bottom of the vessel. This hose enables agitation of the spray solution with each air intake as well as ensures a consistent spray solution.
- L) **Pour 44L of WATER into the vessel FIRST.** Add 1L of colorant (provided). The mixture makes 45L of Colorant Solution ready to use. **DO NOT USE PAINT AS IT WILL CLOG THE SPRAY VALVE!**
- M) Fasten the top vessel’s lid. Ensure that the O-ring is in place.
- N) Ensure that the compressed air ½” isolation valve (Detail “B”) and the pressure regulator (14) on the air inlet line as well as the pressure relief ½” valve (Detail “C”) are closed.
- O) Verify that the pressure regulator valve is closed prior to turning on the compressed air.
- P) Apply the compressed air and adjust the pressure regulator between 4 and 8 bar, as noted on the pressure gauge.
- Q) Open the ½” isolation valve (Detail “D”) on the vessel’s outlet.

5.6.3 Colorant Solution Re-fill Instructions

DO NOT REMOVE THE VESSEL’S LID UNDER PRESSURE!

- A) Refer to Figure 20.
- B) Close the ½” compressed air isolation valve (by the pressure regulator).
- C) Open the ½” pressure relief valve (Detail “C”) and wait until all the compressed air escapes from the pressure vessel.
- D) Remove the vessel’s lid.
- R) **Pour 44L of WATER into the vessel FIRST.** Add 1L of colorant (provided). The mixture makes 45L of Colorant Solution ready to use. **DO NOT USE PAINT AS IT WILL CLOG THE SPRAY VALVE!**
- E) Fasten the vessel’s lid. Ensure that the O-ring is in place.
- F) Close the ½” pressure relief valve (Detail “C”).
- G) Open the ½” compressed air isolation valve (by the pressure regulator).

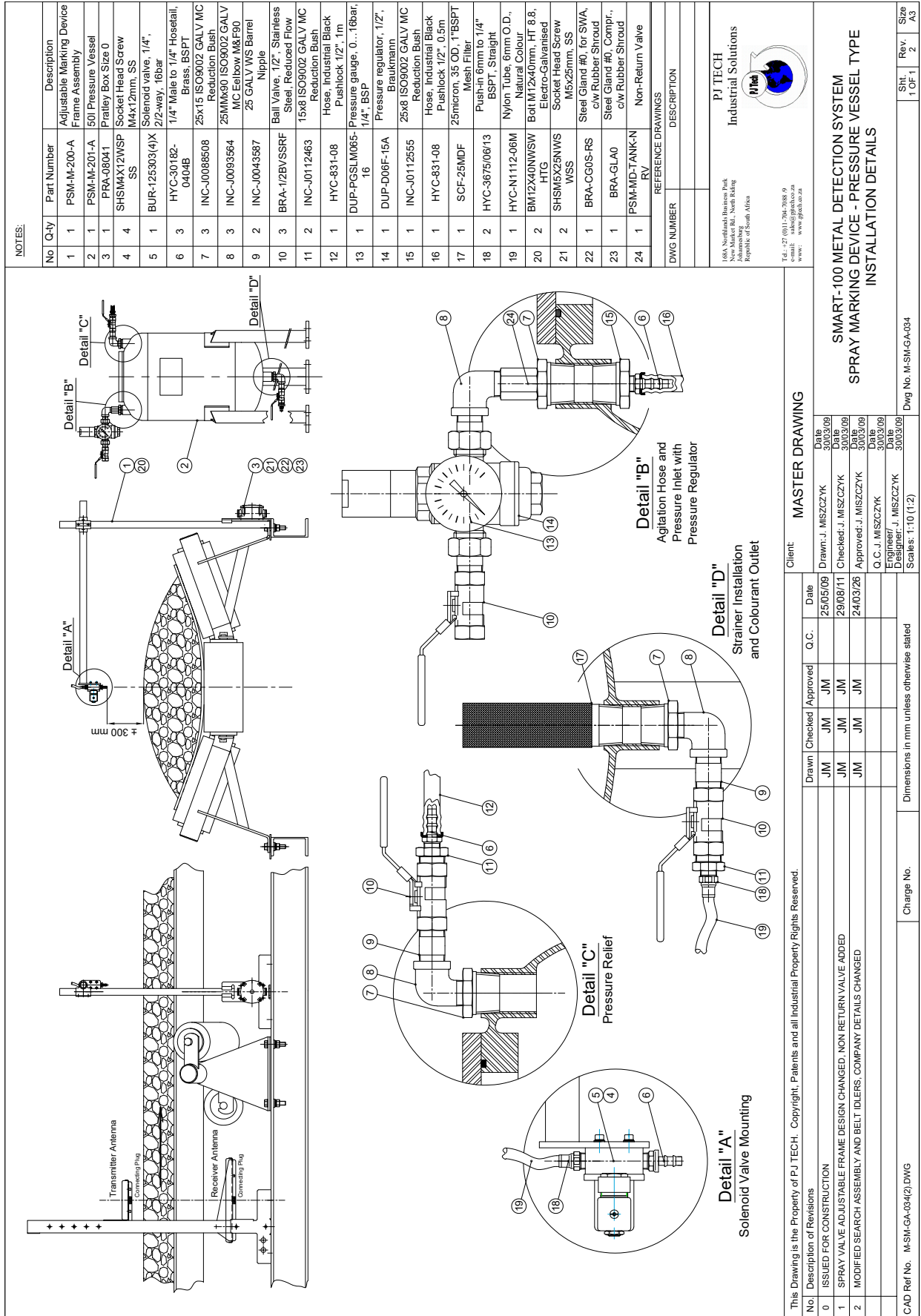

Figure 20

5.7 Spray Marking Device – Pump & Accumulator Type (if applicable)

The Marking Device is a pressurised, solenoid activated liquid spray system which pinpoints the location of tramp metal to eliminate costly search and down time.



*Spray Marking Device – Pump & Accumulator Type
(complete assembly)*

5.7.1 Specifications

Tank Material of Construction:	:	Polyethylene (PE)
Tank Capacity:	:	50L
Operational Voltage (spray valve):	:	110 or 220 VAC (50/60 Hz), 8W
Pump Power Supply	:	100-240Vac (50Hz) 24 to 32W



5.7.2 Installation Instructions

The Tank and Protection Box Assembly that houses the pump and accumulator comes fully assembled from PJ Tech's factory.

- A) Refer to Figure 21 & 22 for installation details and Figure 23 for connection diagram.
- B) Assemble the Marking Device Adjustable Spray Frame (1 on Figure 21) upright and cross arm with the cross bracket.
- C) Fasten the solenoid valve with the spray nozzle (Figure 1 Detail "A") and factory connected 3m cable to the cross bracket with the provided screws and connect the cable to the connectors in the Pratley box. Ensure the excess cable is coiled to allow future adjustments and that the spray nozzle points down, directly above the centre of the conveyor belt.
- D) Connect the 6mm tubing to the solenoid valve (Figure 2 Detail "A"). Ensure the excess tubing is coiled to allow future adjustments.
- E) Position the Adjustable Spray Frame upright and cross arm as shown (1 on Figure 21). It should be located approximately 1m to 2m from the antenna coils (as close as possible to the downstream idler). Bolt the bottom of the Adjustable Spray Frame to the conveyor frame. If necessary, first clamp it in place temporarily.
- F) Bolt the tank frame (2 on Figure 21) to the concrete or steel base or structure (use M12 HT galvanised bolts).
- G) Connect the cable between the spray valve's Pratley box (3 on figure 21) and the field terminals in the Main Control Enclosure (10m SWA, 1mm², 1 pair cable provided). Route the cable accordingly and cut off excess cable. While connecting the wires ensure to put on the provided wire tags.
- H) Connect the tubing between the protection enclosure of the pump & the accumulator (1 on Figure 22) with the spray solenoid valve (Figure 22 "Outlet" & "Return" as well as Figure 21 Detail "A").
- I) Ensure that the 1/4" spray solution pressure relief valve is connected inside the 50L tank (Figure 21 Detail "C"). Ensure that the pressure relief valve is joined with the 6mm tubing and is positioned close to the top of the tank.
- J) Connect the provided pump power supply cable (22 on Figure 21) between the Pratley box (3 on Figure 21) and the Main Control Enclosure (refer to Figure 23 for wire connection details). Ensure that the cable is connected between the pump (4 on Figure 22) and the Pratley box. Use the provided wire tags.
- K) Unscrew the tank's lid and ensure that the 1" 25-micron S/S strainer (15 on Figure 21) is screwed in (inside the tank, at the bottom). This strainer protects blocking of the spray solenoid valve with solid particles that might be present in the added water.
- L) **In above 0°C regions:**
 - **Pour 44L of WATER into the tank FIRST.** Add 1L of colorant (provided) and stir it. Take care while stirring – DON'T DAMAGE the 1" 25-micron S/S strainer at the bottom of the tank. The mixture makes 45L of Colorant Solution ready to use.
DO NOT USE PAINT AS IT WILL CLOG THE SPRAY VALVE!



M) In up to -45°C regions:

- **Pour 44L of WATER with ETHYLENE GLYCOL MIX FIRST** (mix ratio: 60% ethylene glycol and 40% water) with 1L of colorant and stir. Take care while stirring – **DON'T DAMAGE the 1" 25-micron S/S strainer at the bottom of the tank.** The mixture makes 45L of Colorant Solution ready to use. **Freezing point of such mixture is at -45 °C.**
DO NOT USE PAINT AS IT WILL CLOG THE SPRAY VALVE!

N) Screw back the tank's lid on.

O) Ensure that the ¼" isolating purge valve (16 on Figure 22) that is mounted inside the pump & accumulator protection enclosure is closed. Turn on the pump (4 on Figure 22 – "On/Off Switch") and adjust the pump speed via the speed adjustment turn knob on the pump (Figure 22 Detail "B"). During the initial start-up the purge valve should be open for approximately 1 minute to get rid of all the air. Once only the spray solution is visible on the pump outlet tubing (Figure 22, tubing joining the pump with the pressure gauge), close the purge valve. Once the pressure relief valve continuously releases the spray solution into the tank, the Spray Marking Device is ready for operation.

5.7.3 Colorant Solution Re-fill Instructions

A) Refer to Figure 21 & 22.

B) Switch off the pump (4 on Figure 22).

C) Unscrew the tank's lid.

D) In above 0°C regions:

- **Pour 44L of WATER into the tank FIRST.** Add 1L of colorant (provided) and stir it. Take care while stirring – DON'T DAMAGE the 1" 25-micron S/S strainer at the bottom of the tank. The mixture makes 45L of Colorant Solution ready to use.
DO NOT USE PAINT AS IT WILL CLOG THE SPRAY VALVE!

E) In up to -45°C regions:

- **Pour 44L of WATER with ETHYLENE GLYCOL MIX FIRST** (mix ratio: 60% ethylene glycol and 40% water) with 1L of colorant and stir. Take care while stirring – **DON'T DAMAGE the 1" 25-micron S/S strainer at the bottom of the tank.** The mixture makes 45L of Colorant Solution ready to use. **Freezing point of such mixture is at -45°C.**
DO NOT USE PAINT AS IT WILL CLOG THE SPRAY VALVE!

F) Screw back the tank's lid.

G) Ensure that the ¼" purge valve (16 on Figure 22) located in the pump & accumulator's protection enclosure is closed and turn on the pump (4 on Figure 22).

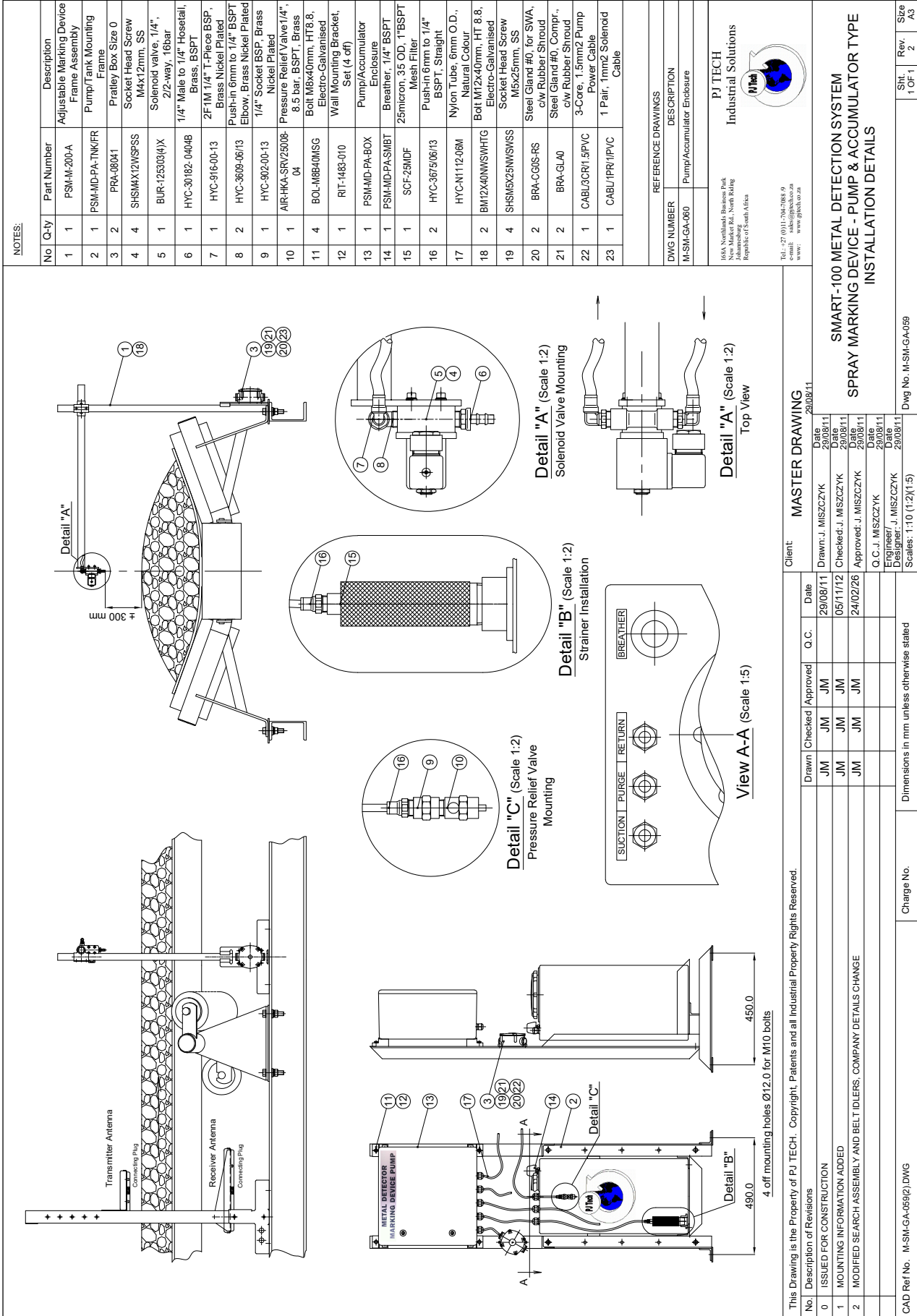

Figure 21

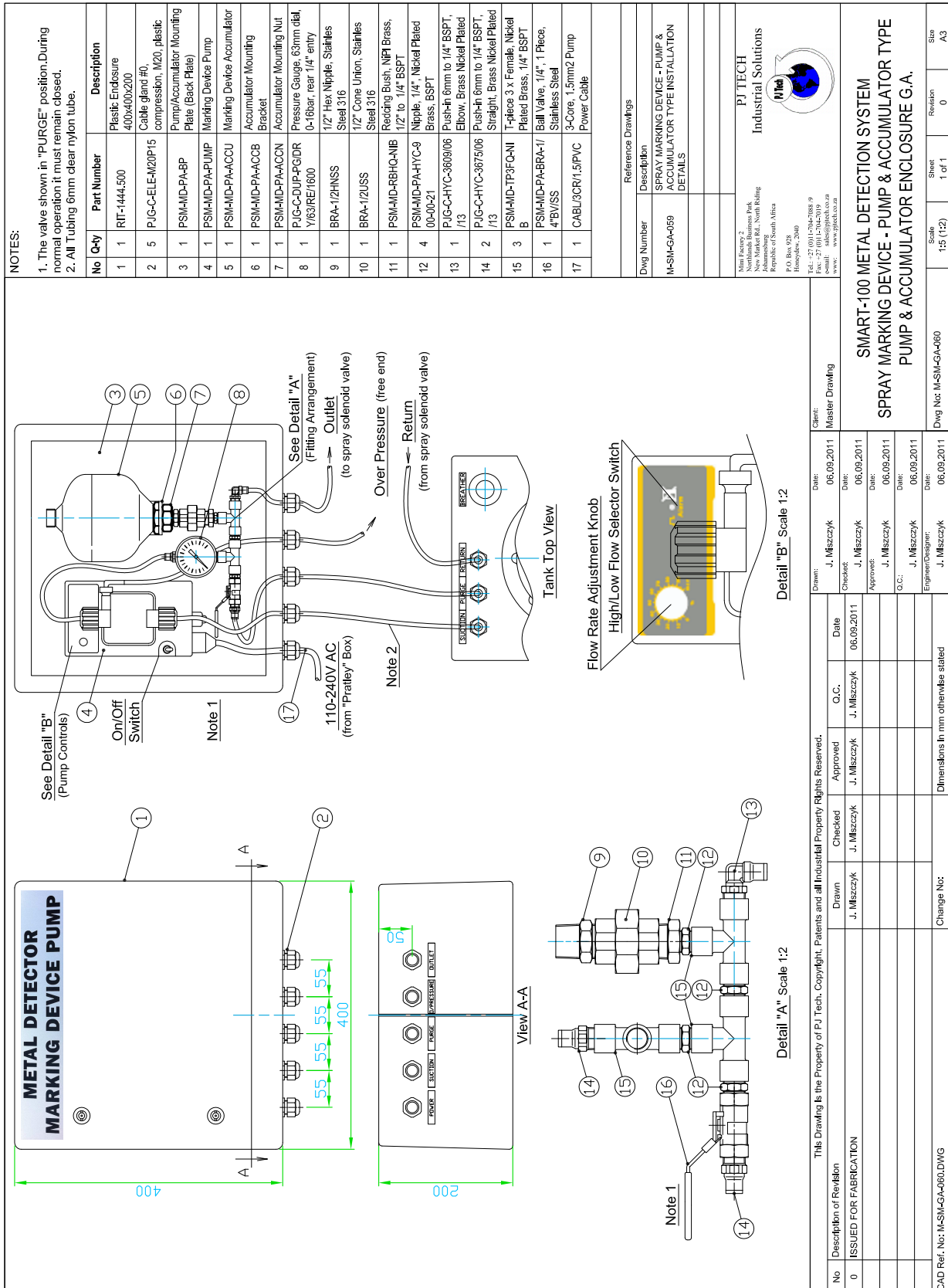
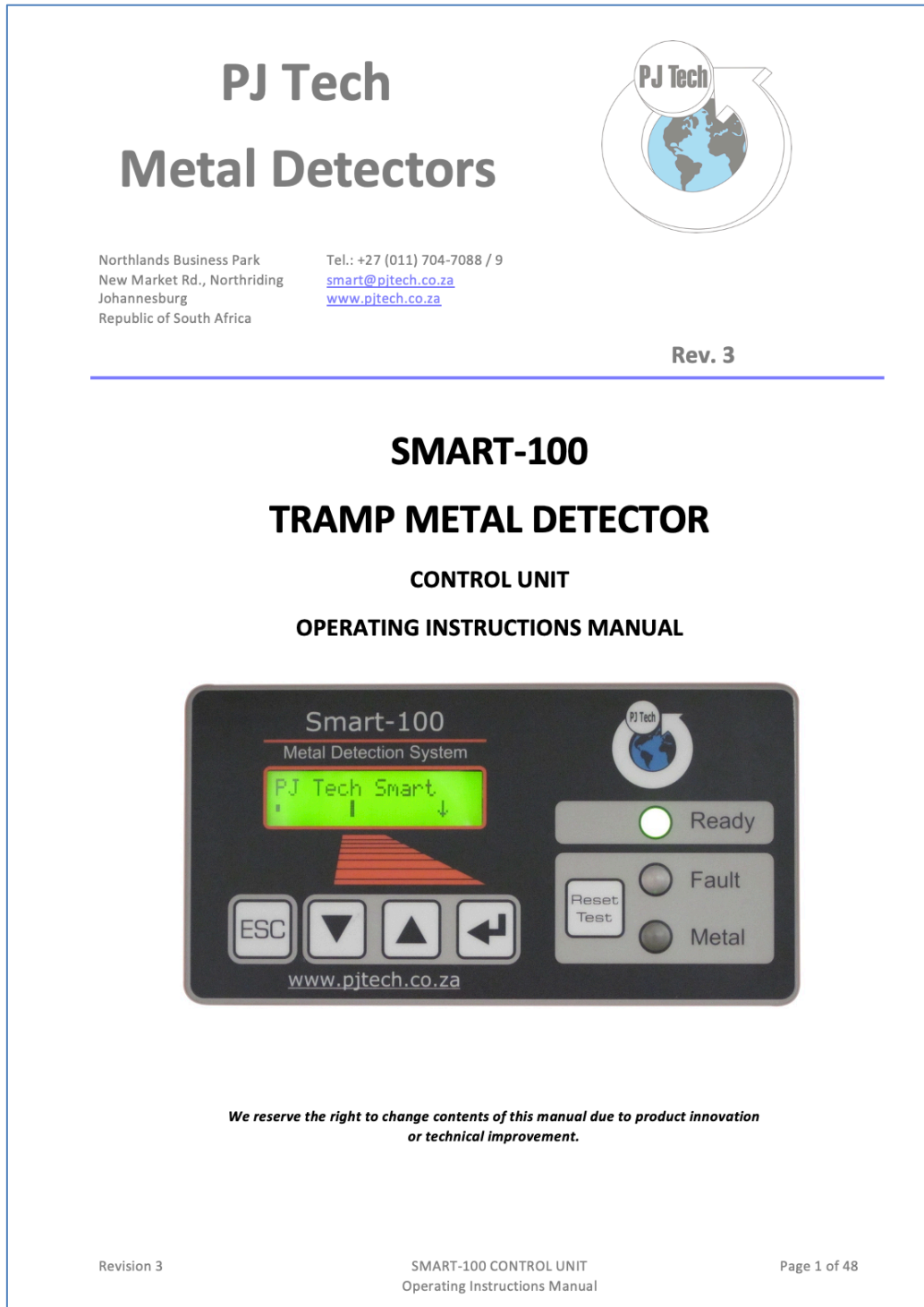

Figure 22



6 START-UP, SETUP & OPERATION

Please refer to Operating Instructions Manual of SMART-100 Control Unit. Downloadable from www.pjtech.co.za.





7 SERVICE, PART REPLACEMENT & REPAIRS

7.1 Goods Return

Please Note: Minimum charge for no fault found will be applicable.

7.1.1 Goods Return Procedure

- A) E-mail an intent to return faulty goods to smart@pjtech.co.za.
- B) Goods being returned **must be clean** - all foreign material must be removed. Any residue could be considered hazardous. If all residue cannot be removed, you **MUST** provide a Material Safety Data Sheet (MSDS) to identify the material, or a signed statement verifying no hazardous residual materials are present.
- C) Return the goods with your GRA form including the obtained **GRA Number**. Ship goods "freight prepaid" – **COLLECT shipments will NOT be accepted**
- D) After examination of the goods, we will send you an official quotation (except warranty repairs). Before any repairs take place, we **MUST** receive an official purchase order.

7.2 Electronics

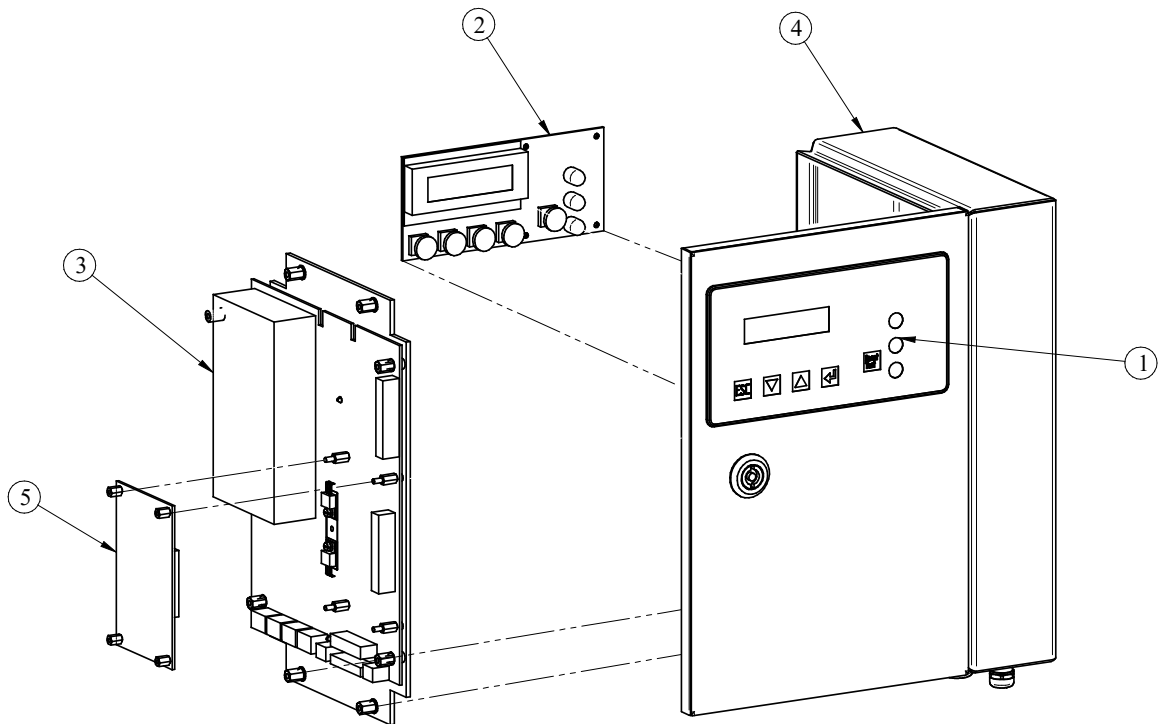

Item No.	Part	Item No.	Remarks Drawing No.
1	Display cover	SM100-CP-LCD-COV	Front plate
2	Display board	SM100-CP-LCD	
3+5	Evaluation electronics with mounting plate & Signal analyser electronics	SM100-CP-CU	
4	Elektronics housing	SM100-CP-BOX	
6	Signal analyser electronics adapter		Optional
7	Display ribbon cable		Not shown



7.3 Antenna Search Frame Assembly

Part numbers of the Frame Coil Assembly depend on the belt with. Please consult PJ TECH for part numbers specific to your installation/s.

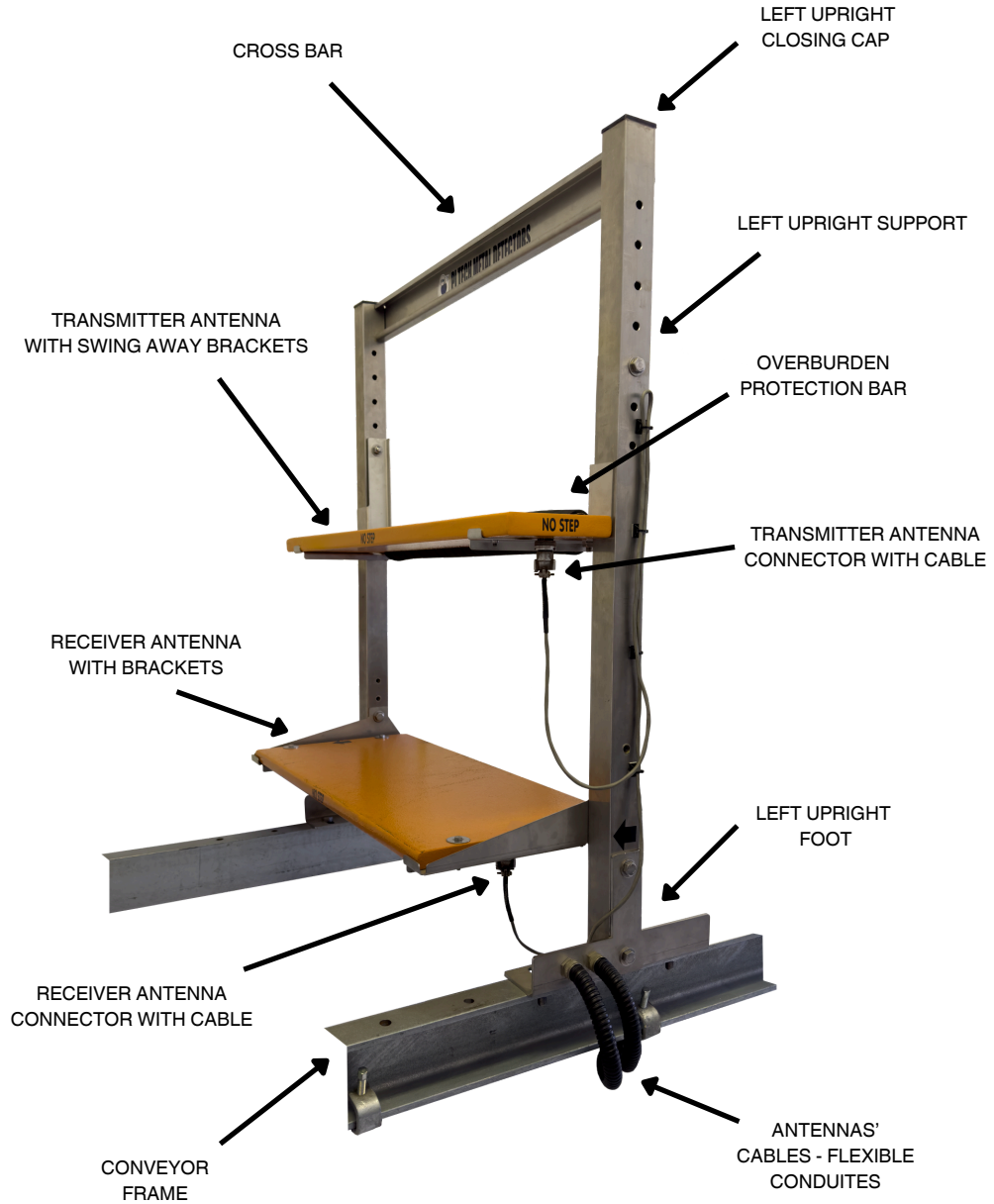



8 NEW APPLICATIONS

Application Check List should be filled in and returned to PJ TECH sales@pjtech.co.za for all new applications.

The application can be downloaded from: <https://pjtech.co.za/metal-detection/application-check-list/> .



9 PJ TECH OTHER SYSTEMS



Northlands Business Park
Northriding
Johannesburg
South Africa

P.O. Box 928
Honeydew, 2040

Tel.: +27 (011) 704-7088
Fax: +27 (011) 704-7019

e-mail: sales@pjtech.co.za
www: www.pjtech.co.za



DUST SUPPRESSION

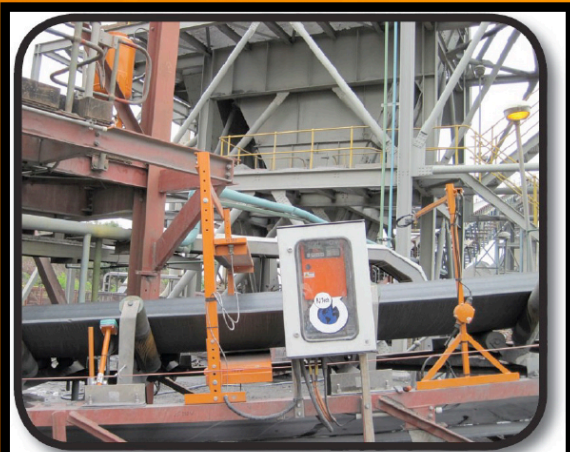

TRAMP METAL DETECTION



**2 in 1
CAP LAMP &
MISSING PERSON LOCATOR**



AIR CANNONS

More information at – www.pjtech.co.za